

THIS DRAWING IS UNPUBLISHED. RELEASED FOR PUBLICATION
 © COPYRIGHT BY TYCO ELECTRONICS CORPORATION. ALL RIGHTS RESERVED.

LOC	DIST	REVISIONS					
G	14	P	LTR	DESCRIPTION	DATE	DWN	APVD
			T2	REV PER ECR 07-006018	20MAR07	JR	TM

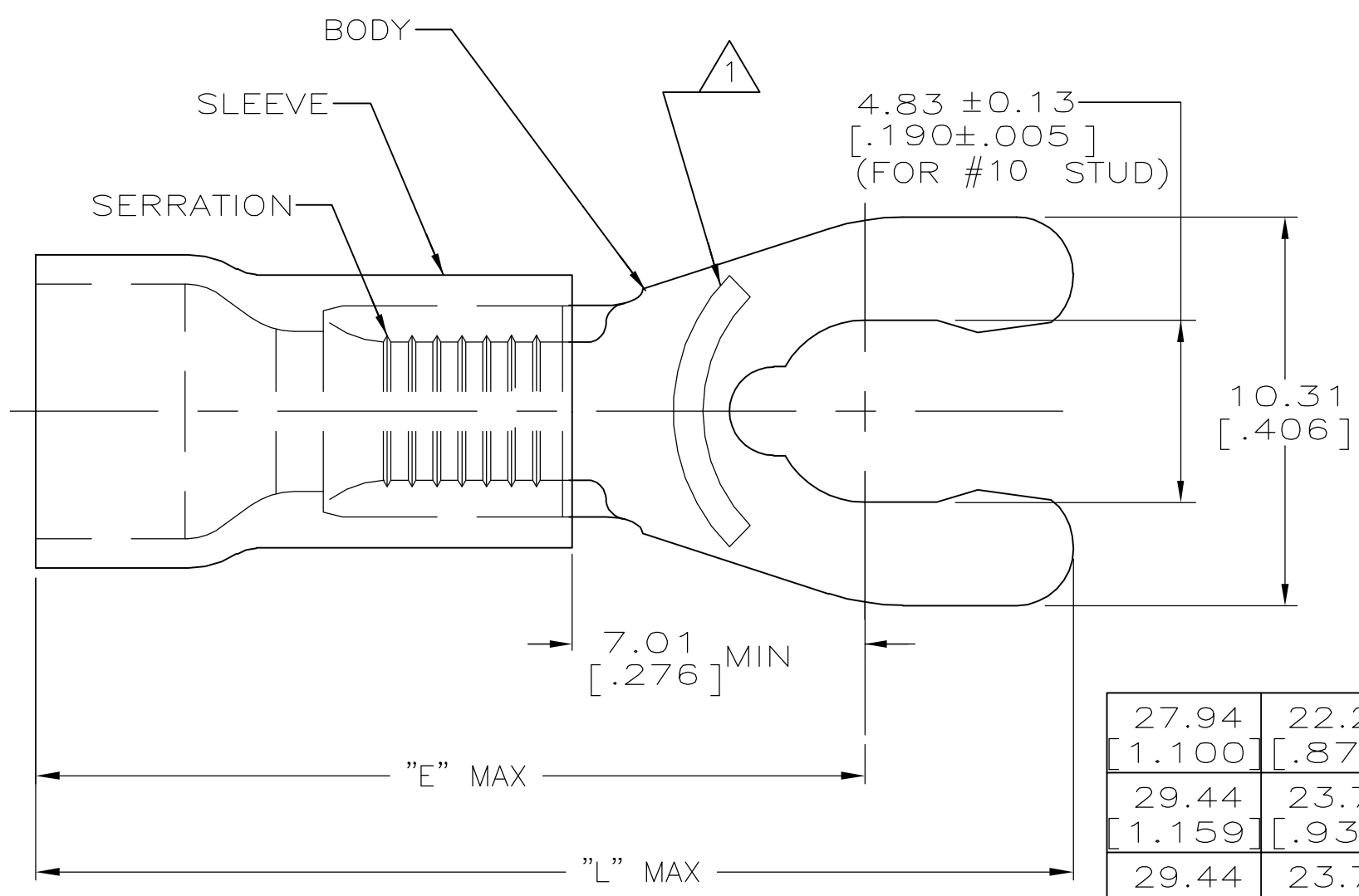

AMP WIRE RANGE	Listed FILE E13288	LR7189 Certified
12-10 AWG SOLID OR STRANDED	12 AWG STRANDED	12-10 AWG SOLID OR STRANDED

- ① STAMP 10S AMP 12-10*APPROX AS SHOWN
- 2. SEE TABLE FOR WIRE INSUL DIA
- 3. TONGUE MATL THK, 1.02±0.05 [.040±.002]
- ④ MATERIAL: BODY - BRASS PER ASTM B36
SLEEVE - PVC, COLOR - YELLOW

27.94 [1.100]	22.28 [.877]	3.81-6.35 [.150-.250]	50	LOOSE PIECE, BOX	8-52963-2
29.44 [1.159]	23.77 [.936]	6.35-7.62 [.250-.300]	1500	ON TAPE, REEL	52963-5
29.44 [1.159]	23.77 [.936]	6.35-7.62 [.250-.300]	500	LOOSE PIECE	52963-4
27.94 [1.100]	22.28 [.877]	3.81-6.35 [.150-.250]	2500	ON TAPE, REEL	52963-3
27.94 [1.100]	22.28 [.877]	3.81-6.35 [.150-.250]	500	LOOSE PIECE	52963-2
27.94 [1.100]	22.28 [.877]	2.67-5.08 [.105-.200]	2500	ON TAPE, REEL	52963-1
27.94 [1.100]	22.28 [.877]	2.67-5.08 [.105-.200]	500	LOOSE PIECE	52963
L	E	WIRE INSUL DIA	QTY	PACKAGE TYPE	PART NO

**AMP INCORPORATED
CUSTOMER SERVICE SYSTEMS**

FOR ADDITIONAL PRODUCT INFORMATION OR COPIES OF DRAWINGS AND TECHNICAL DOCUMENTS: PRODUCT INFORMATION CENTER 1-800-522-6752

FOR APPLICATION TOOLING ASSISTANCE CENTER: TOOLING ASSISTANCE CENTER 1-800-722-1111

FOR ORDER ENTRY: 1-800-526-5142

MAX RECOMMENDED OPERATING TEMPERATURE: 105°C [221°F]

VOLTAGE RATING: 600V MAX (1000V FIXTURE OR SIGN)

CIRCULAR MIL AREA: 2.62-6.64mm² [5,180-13,100] SOLID OR STRANDED

THIS DRAWING IS A CONTROLLED DOCUMENT FOR AMP INCORPORATED. IT IS SUBJECT TO CHANGE AND THE CONTROLLING ENGINEERING ORGANIZATION SHOULD BE CONTACTED FOR THE LATEST REVISION.

THIS DRAWING IS A CONTROLLED DOCUMENT.

DIMENSIONS: mm [INCHES]

TOLERANCES UNLESS OTHERWISE SPECIFIED:

0 PLC	± -
1 PLC	± -
2 PLC	± 0.20 [.008]
3 PLC	± -
4 PLC	± -
ANGLES	± -

MATERIAL: TIN PER ASTM B545

APVD: G NGO

PRODUCT SPEC: UL 486A

APPLICATION SPEC: -

WEIGHT: -

NAME: Tyco Electronics Corporation, Harrisburg, Pa 17105-3608

TERMINAL, SPRING SPADE, SHORT, PLASTI-GRIP WIRE SIZE: 12-10 AWG

SIZE: A3, CAGE CODE: 00779, DRAWING NO: C-52963, RESTRICTED TO: -

CUSTOMER DRAWING, SCALE: 6:1, SHEET: 1 OF 1, REV: T2